



Standard Test Method for Dynamic Young's Modulus, Shear Modulus, and Poisson's Ratio by Sonic Resonance¹

This standard is issued under the fixed designation E1875; the number immediately following the designation indicates the year of original adoption or, in the case of revision, the year of last revision. A number in parentheses indicates the year of last reapproval. A superscript epsilon (ϵ) indicates an editorial change since the last revision or reapproval.

1. Scope*

1.1 This test method covers the determination of the dynamic elastic properties of elastic materials. Specimens of these materials possess specific mechanical resonant frequencies that are determined by the modulus of elasticity, mass, and geometry of the test specimen. Therefore, the dynamic elastic properties of a material can be computed if the geometry, mass, and mechanical resonant frequencies of a suitable test specimen of that material can be measured. Dynamic Young's modulus is determined using the resonant frequency in the flexural mode of vibration. The dynamic shear modulus, or modulus of rigidity, is found using torsional resonant vibrations. Dynamic Young's modulus and dynamic shear modulus are used to compute Poisson's ratio.

1.2 This test method is specifically appropriate for materials that are elastic, homogeneous, and isotropic (1).² Materials of a composite character (particulate, whisker, or fiber reinforced) may be tested by this test method with the understanding that the character (volume fraction, size, morphology, distribution, orientation, elastic properties, and interfacial bonding) of the reinforcement in the test specimen will have a direct effect on the elastic properties. These reinforcement effects must be considered in interpreting the test results for composites. This test method is not satisfactory for specimens that have cracks or voids that are major discontinuities in the specimen. Neither is the test method satisfactory when these materials cannot be fabricated in a uniform rectangular or circular cross section.

1.3 A high-temperature furnace and cryogenic cabinet are described for measuring the dynamic elastic moduli as a function of temperature from -195 to 1200°C .

1.4 Modification of this test method for use in quality control is possible. A range of acceptable resonant frequencies is determined for a specimen with a particular geometry and

mass. Any specimen with a frequency response falling outside this frequency range is rejected. The actual modulus of each specimen need not be determined as long as the limits of the selected frequency range are known to include the resonant frequency that the specimen must possess if its geometry and mass are within specified tolerances.

1.5 There are material-specific ASTM standards that cover the determination of resonance frequencies and elastic properties of specific materials by sonic resonance or by impulse excitation of vibration. Test Methods C215, C623, C747, C848, C1198, and C1259 may differ from this test method in several areas (for example; sample size, dimensional tolerances, sample preparation). The testing of these materials shall be done in compliance with these material specific standards. Where possible, the procedures, sample specifications, and calculations are consistent with these test methods.

1.6 The values stated in SI units are to be regarded as standard. No other units of measurement are included in this standard.

1.7 *This standard does not purport to address all of the safety concerns, if any, associated with its use. It is the responsibility of the user of this standard to establish appropriate safety and health practices and determine the applicability of regulatory limitations prior to use.*

2. Referenced Documents

2.1 ASTM Standards:³

C215 Test Method for Fundamental Transverse, Longitudinal, and Torsional Resonant Frequencies of Concrete Specimens

C623 Test Method for Young's Modulus, Shear Modulus, and Poisson's Ratio for Glass and Glass-Ceramics by Resonance

C747 Test Method for Moduli of Elasticity and Fundamental Frequencies of Carbon and Graphite Materials by Sonic Resonance

¹ This test method is under the jurisdiction of ASTM Committee E28 on Mechanical Testing and is the direct responsibility of Subcommittee E28.04 on Uniaxial Testing.

Current edition approved Nov. 1, 2013. Published May 2014. Originally approved in 1997. Last previous edition approved in 2008 as E1875-08. DOI: 10.1520/E1875-13.

² The boldface numbers in parentheses refer to a list of references at the end of this standard.

³ For referenced ASTM standards, visit the ASTM website, www.astm.org, or contact ASTM Customer Service at service@astm.org. For *Annual Book of ASTM Standards* volume information, refer to the standard's Document Summary page on the ASTM website.

*A Summary of Changes section appears at the end of this standard

- C848** Test Method for Young's Modulus, Shear Modulus, and Poisson's Ratio For Ceramic Whitewares by Resonance
- C1198** Test Method for Dynamic Young's Modulus, Shear Modulus, and Poisson's Ratio for Advanced Ceramics by Sonic Resonance
- C1259** Test Method for Dynamic Young's Modulus, Shear Modulus, and Poisson's Ratio for Advanced Ceramics by Impulse Excitation of Vibration
- E6** Terminology Relating to Methods of Mechanical Testing
- E177** Practice for Use of the Terms Precision and Bias in ASTM Test Methods
- E691** Practice for Conducting an Interlaboratory Study to Determine the Precision of a Test Method

3. Terminology

3.1 *Definitions*: Terms common to mechanical testing.

3.1.1 *dynamic mechanical measurement, n*—a technique in which either the modulus or damping, or both, of a substance under oscillatory applied force or displacement is measured as a function of temperature, frequency, or time, or a combination thereof.

3.1.2 *elastic limit* [FL^{-2}], *n*—the greatest stress that a material is capable of sustaining without permanent strain remaining upon complete release of the stress.

3.1.2.1 *Discussion*—Due to practical considerations in determining the elastic limit, measurements of strain using a small force, rather than zero force, are usually taken as the initial and final reference. **(E6)**

3.1.3 *modulus of elasticity* [FL^{-2}], *n*—the ratio of stress to corresponding strain below the proportional limit.

3.1.3.1 *Discussion*—The stress-strain relationships of many materials do not conform to Hooke's law throughout the elastic range, but deviate therefrom even at stresses well below the elastic limit. For such materials, the slope of either the tangent to the stress-strain curve at the origin or at a low stress, the secant drawn from the origin to any specified point on the stress-strain curve, or the chord connecting any two specified points on the stress-strain curve is usually taken to be the "modulus of elasticity." In these cases, the modulus should be designated as the "tangent modulus," the "secant modulus," or the "chord modulus," and the point or points on the stress-strain curve described. Thus, for materials where the stress-strain relationship is curvilinear rather than linear, one of the four following terms may be used:

(a) *initial tangent modulus* [FL^{-2}], *n*—the slope of the stress-strain curve at the origin.

(b) *tangent modulus* [FL^{-2}], *n*—the slope of the stress-strain curve at any specified stress or strain.

(c) *secant modulus* [FL^{-2}], *n*—the slope of the secant drawn from the origin to any specified point on the stress-strain curve.

(d) *chord modulus* [FL^{-2}], *n*—the slope of the chord drawn between any two specified points on the stress-strain curve below the elastic limit of the material.

3.1.3.2 *Discussion*—Modulus of elasticity, like stress, is expressed in force per unit of area (pounds per square inch, etc.).

3.1.4 *Poisson's ratio, μ , n*—the negative of the ratio of transverse strain to the corresponding axial strain resulting from an axial stress below the proportional limit of the material.

3.1.4.1 *Discussion*—Poisson's ratio may be negative for some materials, for example, a tensile transverse strain will result from a tensile axial strain.

3.1.4.2 *Discussion*—Poisson's ratio will have more than one value if the material is not isotropic. **(E6)**

3.1.5 *proportional limit* [FL^{-2}], *n*—the greatest stress that a material is capable of sustaining without deviation from proportionality of stress to strain (Hooke's law).

3.1.5.1 *Discussion*—Many experiments have shown that values observed for the proportional limit vary greatly with the sensitivity and accuracy of the testing equipment, eccentricity of loading, the scale to which the stress-strain diagram is plotted, and other factors. When determination of proportional limit is required, the procedure and the sensitivity of the test equipment should be specified. **(E6)**

3.1.6 *shear modulus (G)* [FL^{-2}], *n*—the ratio of shear stress to corresponding shear strain below the proportional limit, also called *torsional modulus* and *modulus of rigidity*.

3.1.6.1 *Discussion*—The value of the shear modulus may depend on the direction in which it is measured if the material is not isotropic. Wood, many plastics and certain metals are markedly anisotropic. Deviations from isotropy should be suspected if the shear modulus differs from that determined by substituting independently measured values of Young's modulus, *E*, and Poisson's ratio, μ , in the relation:

$$G = E/[2(1 + \mu)]$$

3.1.6.2 *Discussion*—In general, it is advisable in reporting values of shear modulus to state the range of stress over which it is measured.

3.1.7 *Young's modulus (E)* [FL^{-2}], *n*—the ratio of tensile or compressive stress to corresponding strain below the proportional limit of the material. **(E6)**

3.2 *Definitions of Terms Specific to This Standard:*

3.2.1 *anti-nodes, n*—two or more locations in an unconstrained slender rod or bar in resonance that have local maximum displacements.

3.2.1.1 *Discussion*—For the fundamental flexure resonance, the anti-nodes are located at the two ends and the center of the specimen.

3.2.2 *elastic, adj*—the property of a material such that an application of stress within the elastic limit of that material making up the body being stressed will cause an instantaneous and uniform deformation that will be eliminated upon removal of the stress, with the body returning instantly to its original size and shape without energy loss.

3.2.2.1 *Discussion*—Most elastic materials conform to this definition well enough to make this resonance test valid.

3.2.3 *flexural vibrations, n*—oscillations that occur in a slender rod or bar in a vertical plane normal to the length dimension.

3.2.4 *homogeneous, adj*—the condition of a specimen such that the composition and density are uniform, such that any smaller specimen taken from the original is representative of the whole.

3.2.4.1 *Discussion*—Practically, as long as the geometrical dimensions of the test specimen are large with respect to the size of individual grains, crystals, or components, the body can be considered homogeneous.

3.2.5 *isotropic, adj*—the condition of a specimen such that the values of the elastic properties are the same in all directions in the material.

3.2.5.1 *Discussion*—Materials are considered isotropic on a macroscopic scale, if they are homogeneous and there is a random distribution and orientation of phases, crystallites, and components.

3.2.6 *nodes, n*—one or more locations of a slender rod or bar in resonance that have a constant zero displacement.

3.2.6.1 *Discussion*—For the fundamental flexural resonance, the nodes are located at $0.224 L$ from each end, where L is the length of the specimen.

3.2.7 *resonance, n*—state of slender rod or bar driven into one of the modes of vibration described in 3.2.3 or 3.2.9 when the imposed frequency is such that the resultant displacements for a given amount of driving force are at a maximum.

3.2.7.1 *Discussion*—The resonant frequencies are natural vibration frequencies that are determined by the modulus of elasticity, mass, and dimensions of the test specimen.

3.2.8 *slender rod or bar, n*—in dynamic elastic property testing, a specimen whose ratio of length to minimum cross-sectional dimension is at least five and preferably in the range from 20 to 25.

3.2.9 *torsional vibrations, n*—oscillations that occur in each cross-sectional plane of a slender rod or bar, such that the plane twists around the length dimension axis.

4. Summary of Test Method

4.1 This test method measures the resonant frequencies of test specimens of suitable geometry by exciting them at continuously variable frequencies. Mechanical excitation of the bars is provided through the use of a transducer that transforms a cyclic electrical signal into a cyclic mechanical force on the specimen. A second transducer senses the resulting mechanical vibrations of the specimen and transforms them into an electrical signal. The amplitude and frequency of the signal are measured by an oscilloscope or other means to detect resonance. The resonant frequencies, dimensions, and mass of the specimen are used to calculate dynamic Young's modulus and dynamic shear modulus.

5. Significance and Use

5.1 This test method has advantages in certain respects over the use of static loading systems for measuring moduli.

5.1.1 This test method is nondestructive in nature. Only minute stresses are applied to the specimen, thus minimizing the possibility of fracture.

5.1.2 The period of time during which measurement stress is applied and removed is of the order of hundreds of

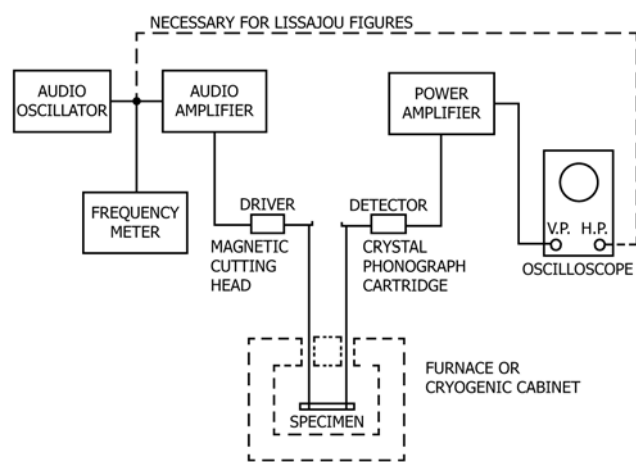

FIG. 1 Block Diagram of a Typical Test Apparatus

microseconds. With this test method it is feasible to perform measurements at high temperatures, where delayed elastic and creep effects would invalidate modulus of elasticity measurements calculated from static loading.

5.2 This test method is suitable for detecting whether a material meets the specifications, if cognizance is given to one important fact in materials are often sensitive to thermal history. Therefore, the thermal history of a test specimen must be considered in comparing experimental values of moduli to reference or standard values. Specimen descriptions should include any specific thermal treatments that the specimens have received.

6. Apparatus

6.1 The test apparatus is shown in Fig. 1. It consists of a variable-frequency audio oscillator, used to generate a sinusoidal voltage, and a power amplifier and suitable transducer to convert the electrical signal to a mechanical driving vibration. A frequency meter (preferably digital) monitors the audio oscillator output to provide an accurate frequency determination. A suitable suspension-coupling system supports the test specimen. Another transducer acts to detect mechanical vibration in the specimen and to convert it into an electrical signal that is passed through an amplifier and displayed on an indicating meter. The meter may be a voltmeter, microammeter, or oscilloscope. An oscilloscope is recommended because it enables the operator to positively identify resonances, including higher order harmonics, by Lissajous figure analysis. If a Lissajous figure is desired, the output of the oscillator is also coupled to the horizontal plates of the oscilloscope. If temperature-dependent data are desired, a suitable furnace or cryogenic chamber is used. Details of the equipment are as follows:

6.2 *Audio Oscillator*, having a continuously variable frequency output from about 100 Hz to at least 30 kHz. Frequency drift shall not exceed 1 Hz/min for any given setting.

6.3 *Audio Amplifier*, having a power output sufficient to ensure that the type of transducer used can excite any specimen the mass of which falls within a specified range.